

R 1010

911 HARNESS GUIDE BAR INSTALLATION INSTRUCTIONS

Note: This harness guide bar is designed to fit all Porsche 911 models with shoulder belts, excluding Targa and Cabriolet. This bar is designed to be a harness guide bar, do not mount the harness directly to this bar.

Step 1

Remove both shoulder strap "D" rings. Do this by unsnapping the plastic escutcheon on each "D" ring to expose the mounting bolt. Remove the bolt, "D" ring and washer/ washers together because they will be re-attached the same way they came off.

Step 2

Position the guide bar between the pillars, lining up the "D" ring mounting holes with the holes in the harness guide bar.

Step 3

Reinstall the "D" rings and their mounting hardware. Torque bolts to factory specifications. Reinstall escutcheons.

Step 4

Once all of the hardware is installed and the bar is positioned properly, use a 5/16" allen key to snug the bar clamp. Do not over tighten. This only has to be tight enough to clamp the free end of the bar to hold its position for ease of future removal and installation .

Performance driving events are by nature potentially hazardous to your health. Brey-Krause Mfg. Co. Inc. shall not be liable for injury, consequential, or other types of damages resulting from the use or misuse of our products. Proper installation of these parts is critical and should only be done by a professional shop.

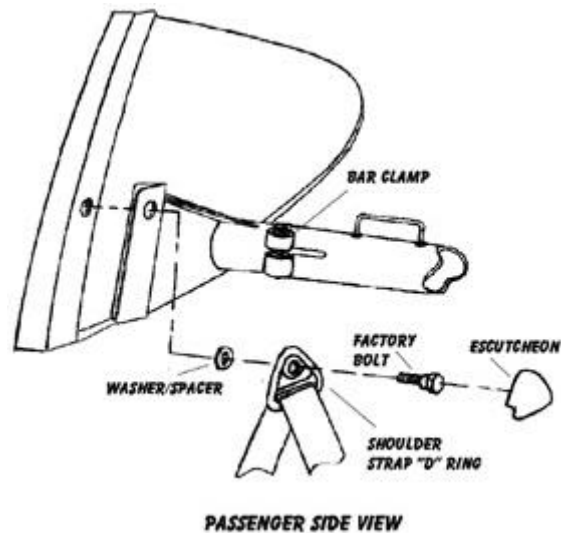

* ORIGINAL EQUIPMENT

Note: Factory hardware varies from year to year. The orientation shown may not match yours. Reinstall original hardware the way it came off.